

## ARCADE • SUSPENSION SNOOKER

REF. 9880. 150x40

### WEIGHT

Net Weight: 48kg | 105 lbs  
 Gross Weight: 82kg | 180 lbs

### BULBS

Quantity: 28  
 Type: G9  
 Wattage: 40W (max)

### GLASS

Type: Clear

### MATERIALS

Body: Brass  
 Details: Glass

### PACKING (approx.)

Dimensions: 161 x 63 x 59 cm  
 63.3 x 24.8 x 23.2 in

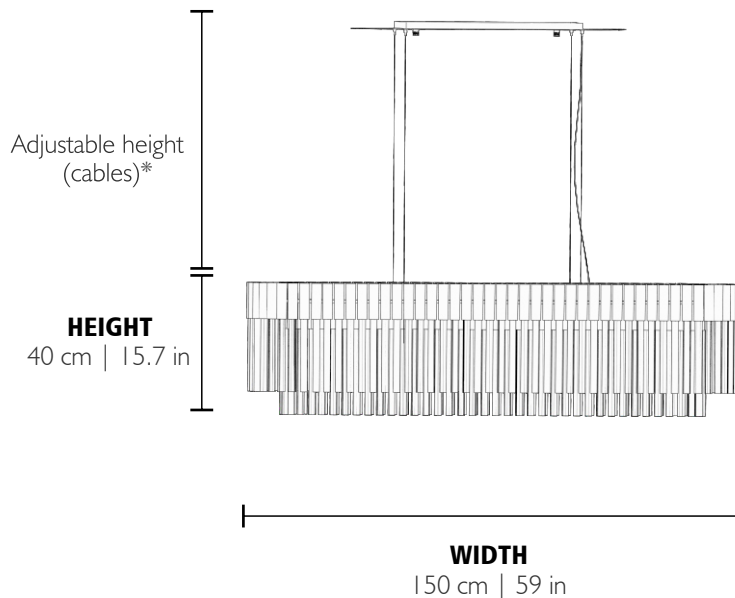

CE - Products manufactured according the European norm of security EN 60 598-1.

F - Products adjusted for installation in surfaces normally inflammable.

□ - Products of class II. The electric isolation is double or reinforced.

ES - Products with the possibility of instalation of low-energy consumption bulbs.

\*Standard cable length: 2m.

## PRODUCT FINISHES & COSTUMIZATION OPTIONS

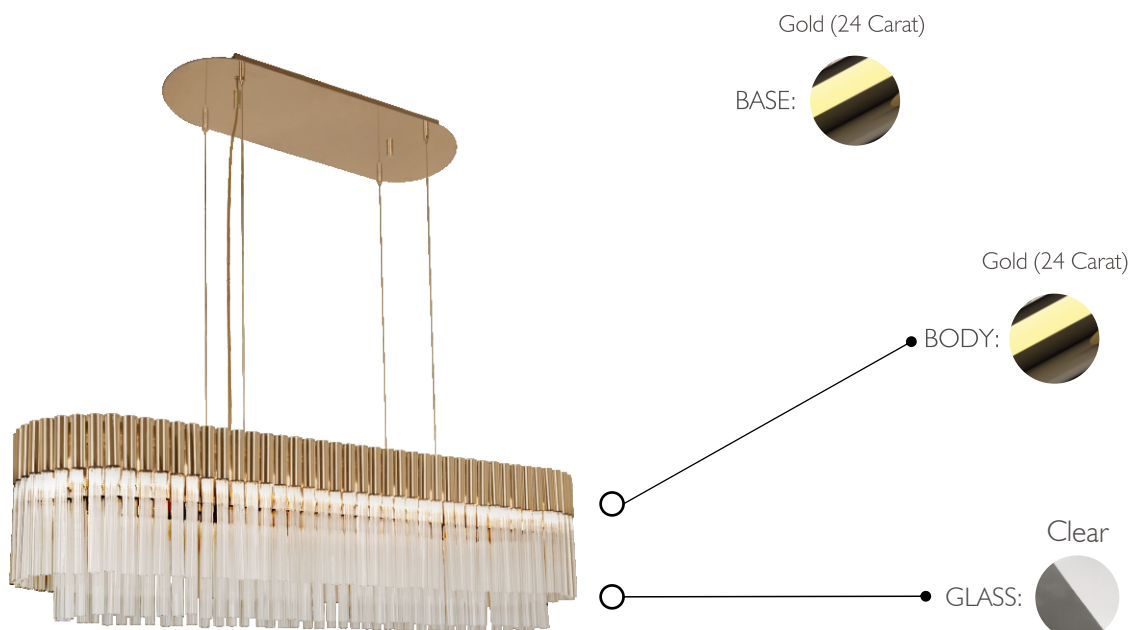

MORE FINISHES AVAILABLE HERE:

[CLICK HERE](#) 